

Agilent

Digitizers

Agilent Technologies
High-Speed, High Resolution and USB Digitizers



Agilent Technologies

Agilent Digitizers lead the market in performance and breadth of offering



High-Speed Digitizers provide a range of 500 MS/s, 1 GS/s, 2 GS/s, 4 GS/s and 8 GS/s high-speed digitizer cards with 8-, 10- and 12-bit resolution, wide bandwidths and large acquisition memories. These products, in PCI, PXI, cPCI, and VME formats, are used in research, ATE and OEM applications in industries as wide spread as Biotechnology, Semiconductors, Aerospace, Physics, and Astronomy. Configured together into a data acquisition system, the high-speed digitizers deliver essential multichannel oscilloscope capabilities in a compact modular package, providing a wide range of functionalities that can not be matched by monolithic instruments. The whole system includes a fast PC connection and all the necessary software for a simple integration into any automated test system.



High Resolution Digitizers provide mid-range sample rates that compliment instruments in test systems such as DMMs, function generators, switch systems and counters. The digitizers provide high resolution for accurate waveform acquisition and on-board measurements in a new stand-alone LXI format. These digitizers are used in Automotive, Aerospace/Defense, Medical and Electronic Test applications.



U2500A Series USB Simultaneous Sampling Multifunction Data Acquisition gives you the choice and flexibility to create standalone or modular solutions that expand and evolve according to your test requirement needs. These modules provide from 250 kS/s up to 2 MS/s with additional Analog Output and Digital IO functionality that is simple enough for academic application and yet robust and versatile enough for use in applications in Medical, Consumer Electronics, Electronic Test, Construction, and Automotive industries.

	Model	Maximum Sample Rate	ADC Resolution	Form Factor	See more
High Speed , High Resolution and USB Digitizers	U1064A	4 GS/s	8 bits	cPCI	Pages 04-05
	U1065A	8 GS/s	10 bits	cPCI	Pages 06-07
	U1066A	400 MS/s	12 bits	cPCI	Pages 08-09
	U1061A	2 GS/s	8 bits	PXI	Pages 10-11
	U1062A	4 GS/s	10 bits	PXI	Pages 12-13
	U1056B		N/A		Pages 14-15
	U1071A	2 GS/s	8 bits	PCI	Pages 16-17
	U1070A	400 MS/s	12 bits	PCI	Pages 18-19
	U1080A	2 GS/s	8 bits	cPCI	Pages 20-21
	U1082A	2 GS/s	8 bits	PCI	Pages 22-23
	L4532A	20 MS/s	16 bits	LXI	Pages 24-25
	L4534A	20 MS/s	16 bits	LXI	Pages 26-27
	U2531A	2 MS/s	14 bits	USB	Pages 28-29
	U2541A	250 kS/s	16 bits	USB	Pages 30-31
U2542A	500 kS/s	16 bits	USB	Pages 32-33	
Digitizer Application Examples					Pages 34-35



CompactPCI High-Speed Multichannel Digitizers with 28-channel Synchronization Capability



U1064A-004 Acqiris Quad-Channel, 1-4 GS/s High-Speed Digitizer

- 1 GHz bandwidth
- Acquisition memory from 128-512 kSample up to 8-32 MSample (optional)

U1064A-002 Acqiris Dual-Channel, 2-4 GS/s High-Speed Digitizer

- 1 GHz bandwidth
- Acquisition memory from 256-512 kSample up to 16-32 MSample (optional)

U1064A-001 Acqiris Single-Channel, 4 GS/s High-Speed Digitizer

- 150 MHz bandwidth
- Acquisition memory from 128 kSample up to 2 MSample (optional)

U1064A 4 GS/s 8-bit High-Speed cPCI Digitizer

Models and specifications

	U1064A-001	U1064A-002	U1064A-004
Sample Rate	100 S/s to 1 GS/s in 1, 2, 2.5, 4, 5 sequence and 2 GS/s, 4 GS/s		
Resolution	8-bit		
Bandwidth	-F50 front-end option: DC to 1 GHz -FHZ front-end option: 50 Ω: DC to 950 MHz 1 MΩ: DC to >300 MHz (typ.)		
Number of channels	Single at 4 GS/s	Single at 4 GS/s Dual at 2 GS/s	Single at 4 GS/s Dual at 2 GS/s Quad at 1 GS/s
Voltage Input	50 Ω: 50 mV to 5 V 1 MΩ: 50 mV to 50 V		
On-board Measurements	N/A		
Memory	512 kSamples	256 kSamples/channel	128 kSamples/channel
Optional memory	32 MSamples/channel	16 MSamples/channel	8 MSamples/channel

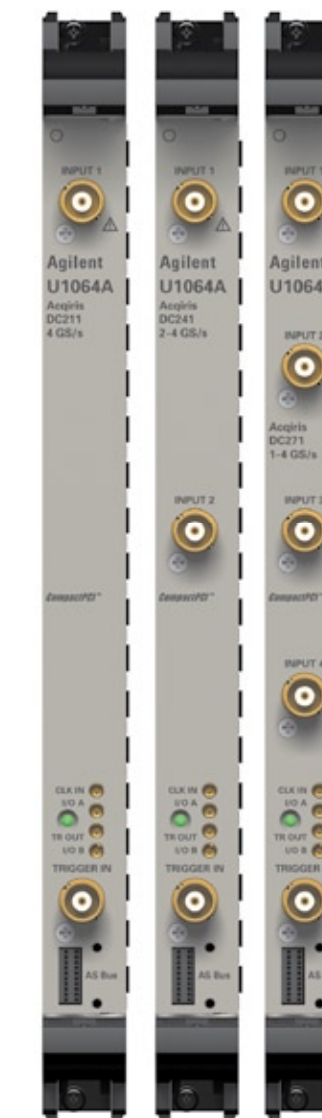

Choice of mezzanine front-ends with input protection and internal DC calibration

Options and Accessories

- U1064A-F50 Standard front-end, 50 Ω, 1 GHz
- U1064A-FHZ High-impedance front-end, 50 Ω/1 MΩ, 1 GHz/300MHz
- U1064A-M8M 2 to 8 MSample acquisition memory option
- U1064A-M32M 8 to 32 MSample acquisition memory option
- U1064A-BB1 Battery back-up

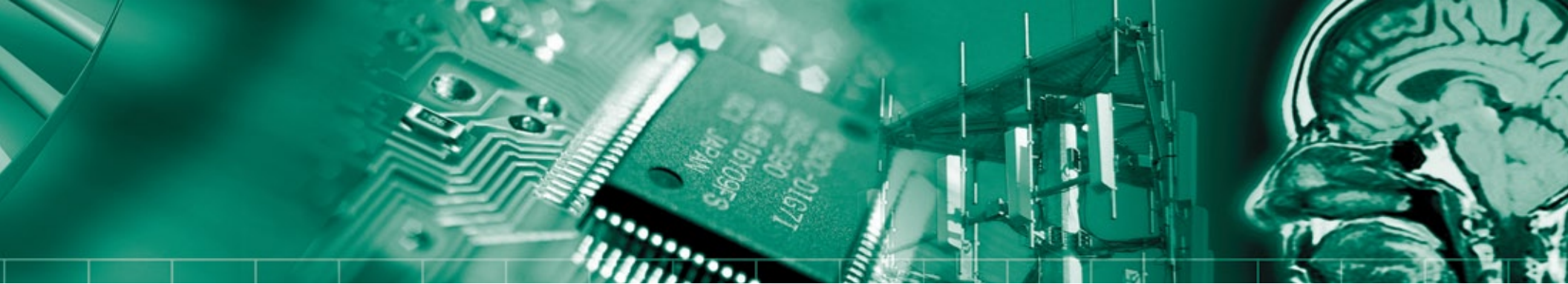

10-bit CompactPCI Digitizers with Sampling of up to 8 GS/s



U1065A-004 Acqiris Quad-Channel, 2-8 GS/s High-Speed Digitizer

- 2 GHz bandwidth with 50 Ω standard front end
- 1 GHz/300 MHz bandwidth with 50 Ω /1 M Ω high-impedance front end
- Acquisition memory from 256-1024 kSample up to 256-1024 MSample (optional)

U1065A-002 Acqiris Dual-Channel, 4-8 GS/s High-Speed Digitizer

- 2 GHz bandwidth with 50 Ω standard front end
- 3 GHz bandwidth with 50 Ω high-frequency front end
- Acquisition memory from 512-1024 kSample up to 512-1024 MSample (optional)

U1065A-001 Acqiris Single-Channel, 8 GS/s High-Speed Digitizer

- 2 GHz bandwidth with 50 Ω standard front end
- 3 GHz bandwidth with 50 Ω high-frequency front end
- Acquisition memory from 1024 kSample up to 1024 MSample (optional)

U1065A 8 GS/s 10-bit High-Speed cPCI Digitizer

Models and specifications

	U1065A-001	U1065A-002	U1065A-004
Sample Rate	100 S/s to 2 GS/s in 1, 2, 2.5, 5 sequence and 4 GS/s, 8 GS/s		
Resolution	10-bit		
Bandwidth	F50 front-end option: DC to 2 GHz 50 Ω : DC to 950 MHz 1 M Ω : DC to > 300 MHz (typ.)		
Number of channels	Single	Dual	Quad
Voltage Input	50 Ω : 50 mV to 5 V 1 M Ω : 50 mV to 50 V		
On-board Measurements	N/A		
Memory	256 kSamples	512 kSamples/channel	1024 kSamples/channel
Optional memory	256 MSamples/channel	512 MSamples/channel	1024 MSamples/channel

Precision time base

Each digitizer has a precision crystal-controlled time base. Sample rates can be selected, in a 1, 2, 2.5, 5 sequence, from 100 S/s to 2 GS/s plus 4 GS/s and 8 GS/s. An internal trigger time interpolator (TTI) with high timing resolution is used to assist with trigger time measurements and positioning with respect to the internal clock (sampling time). The sampling clock can also be generated externally, using the dedicated MMCX CLK IN connector, for applications where the sample rate must be synchronized with the signal to be acquired. The digitizers feature a sequence acquisition mode that allows the capture and storage of consecutive "single" waveforms. In sequence acquisition mode the acquisition memory is divided into segments. Waveforms are stored in successive memory segments as they arrive. The memory can be divided into any number of segments between 2 and 1000 (up to 16000 segments with the 128 M memory option, and 125000 segments with 1G memory option). Sequence acquisition mode is extremely useful in almost all impulse-response type applications such as radar, sonar, lidar, time-of-flight, ultrasonics, medical and biomedical research.

Fast data throughput

The memory and acquisition controller component is a digital CMOS integrated circuit. A high-speed data demultiplexer with on-board memory, it is designed to capture and memorize 10-bit digital data, at speeds of up to 2 GS/s. It has a large internal static RAM, high clock frequencies, and it is able to accept and generate low-voltage differential signal levels (LVDS) with a range of 100 mV to 600 mV for fast input/output signals. The circuit allows storage of the input data stream to a self-addressed, 10-bit, 256 kSample internal memory. The U1065A digitizer has provision for external memory expansion of up to 1 GSsample.

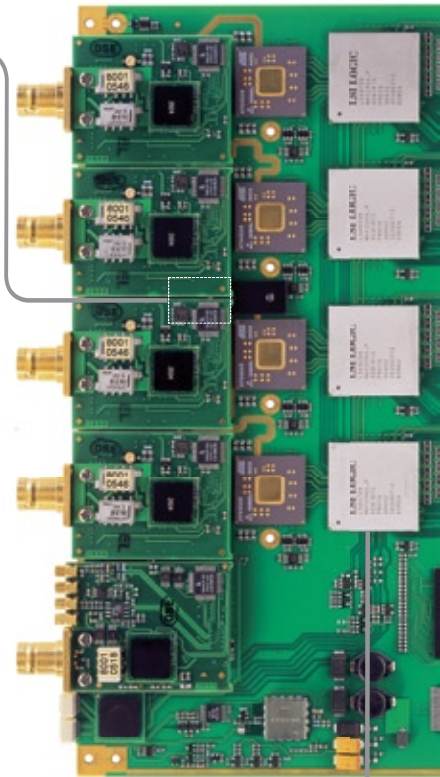

Options and Accessories

- U1065A-F50 Standard front-end for DC222, DC252 and DC282, 2 GHz
- U1065A-FHZ High-impedance front-end for DC282, (50 Ω /1 M Ω)
- U1065A-FHF High-frequency front-end for DC222 and DC252, 3 GHz
- U1065A-128 32 to 128 MSample acquisition memory option for -F50 and -FHF front-end
- U1065A-M1G 256 to 1024 MSample acquisition memory option for -F50 and -FHF front-end



12-bit CompactPCI Digitizers with Amazing Speed and Accuracy



U1066A-001 Acqiris Dual-Channel, 400 MS/s High-Speed Digitizer

- 100 MHz DC-coupled standard input, 300MHz AC-coupled HF input
- 4 MSample acquisition memory

U1066A-002 Acqiris Dual-Channel, 200 MS/s High-Speed Digitizer

- 100 MHz bandwidth
- 4 MSample acquisition memory

U1066A 400 MS/s 12-bit High-Speed cPCI Digitizer

Models and specifications

	U1066A-001	U1066A-002
Sample Rate	100 S/s to 500 MS/s	100 S/s to 1 GS/s in 1, 2, 2.5, 4, 5 sequence
Resolution	8-bit	
Bandwidth	DC to 150 MHz \geq 100 mV FS	DC to 250 MHz \geq 100 mV FS > 90 MHz at 50 mV FS
Number of channels	Quad at 500 MS/s	Quad at 1 GS/s
Voltage Input	50 Ω : 250 mV to 10 V	
On-board Measurements	N/A	
Memory	2 MSamples/channel	128 kSamples/channel
Optional memory	N/A	8 MSamples/channel

FFT analysis: standard input

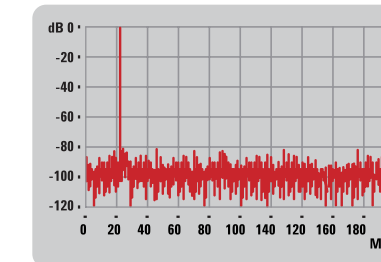

FFT analysis: HF input

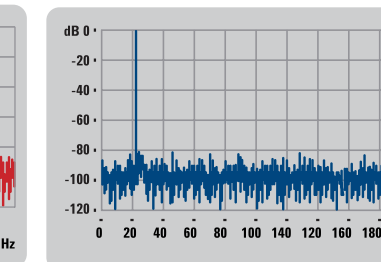

Figure 1 and 2: FFT analysis of a pure 25 MHz sinewave at 400 MS/s shows amazingly low noise floor, extremely high SFDR and little harmonic distortion for both the standard and high-frequency inputs (U1066A-001 only).

Frequency response: standard input

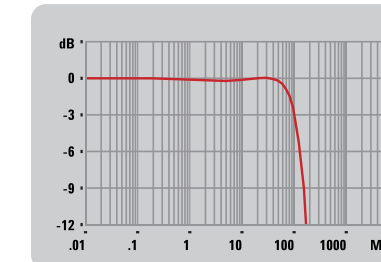

Figure 3: Frequency response for standard input is flat and system bandwidth for 1 V FS exceeds the specified 100 MHz.

Frequency response: HF input

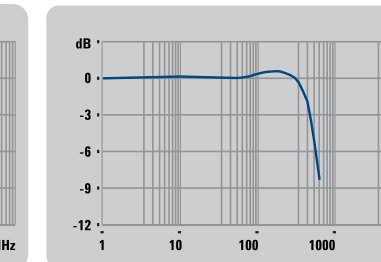

Figure 4: Frequency response of HF input shows system bandwidth above the specified 300 MHz (U1066A-001 only).

SFDR & THD: standard input, HF input

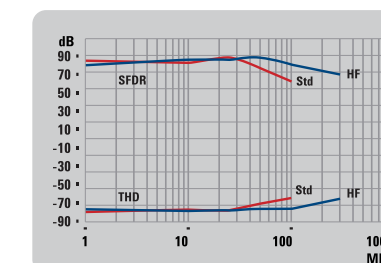

Figure 5: SFDR & THD values at 170 MS/s SR and 80% of 1 V FS are remarkably high for both the standard and HF inputs (U1066A-001 only).

Effective bits: standard input, HF input

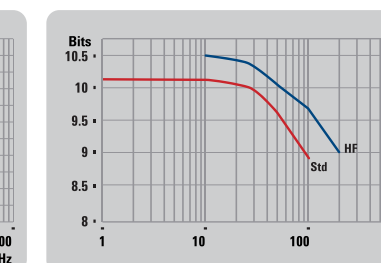

Figure 6: Effective bits at 170 MS/s SR and 80% of 1 V FS are well above 10 for both the standard and HF inputs (U1066A-001 only).

Options and Accessories

- U1066A-M8M 8 MSample acquisition memory option
- U1066A-BB1 Battery back-up



The Standard for 3U Single-slot High-Speed PXI Digitizers

U1061A-002 Acqiris Dual-Channel, 1-2 GS/s High-Speed Digitizer

- 1 GHz bandwidth
- Acquisition memory from 128-256 kSample up to 8-16 MSample (optional)
- Software support for easy integration

U1061A-001 Acqiris Dual-Channel, 0.5-1 GS/s High-Speed Digitizer

- 500 MHz bandwidth
- Acquisition memory from 64-128 kSample up to 2-4 MSample (optional)
- Software support for easy integration



U1061A 2 GS/s 8-bit High-Speed PXI Digitizer

Models and specifications

	U1061A-001	U1061A-002
Sample Rate	100 S/s to 1 Gs/s	100 S/s to 2 Gs/s
Resolution	8-bit	
Bandwidth	DC to 500 MHz	DC to 1 GHz
Number of channels	2 at 500 Ms/s	2 at 1 Gs/s
Voltage Input	50 Ω: 50 mV to 5 V 1 MΩ: 50 mV to 50 V	
On-board Measurements	Frequency Counter (optional)	
Memory	64 kSamples/channel	128 kSamples/channel
Optional memory	2 MSamples/channel	16 MSamples/channel

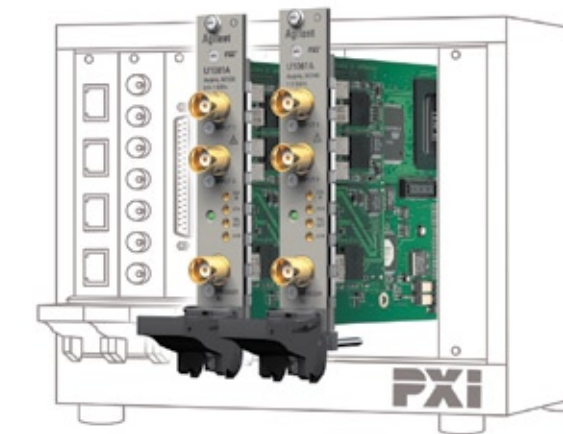

Single-Slot High-Speed Data Acquisition

Agilent Acqiris high-speed U1061A PXI digitizers use the latest SiGe (silicon-germanium) technology to provide superior data conversion performance in single-slot PXI 3U modules. They can be plugged directly into any PXI or CompactPCI crate and can be quickly integrated into any system.

The digitizers' ultra-fast sampling rates and bandwidths combine to allow the accurate capture of signals up to 1 GHz. Moreover, with long acquisition memories up to 16 MSample, it is possible to record complex signals over long periods of time.

Options and Accessories

- U1061A-M16 16 MSample acquisition memory for U1061A-002
- U1061A-M4M 4 MSample acquisition memory for U1061A-001
- U1061A-FC1 Frequency counter firmware



The World's First 10-bit 4 GS/s 3U PXI Digitizers for Fast RF and ATE Applications



U1062A-002 Acqiris Dual-Channel, 4 GS/s High-Speed Digitizer

- 2 GHz bandwidth
- Acquisition memory from 256-512 kSample up to 256-512 MSample (optional)
- Software support for easy integration

U1062A-001 Acqiris Single-Channel, 4 GS/s High-Speed Digitizer

- Standard input option, with 2 GHz bandwidth, 50 Ω, DC or AC-coupled, with internal DC calibration
- Acquisition memory from 512 kSample up to 512 MSample (optional)
- Software support for easy integration

U1062A 4 GS/s 10-bit High-Speed PXI Digitizer

Models and specifications

	U1062A-001	U1062A-002
Sample Rate	100 S/s to 2 GS/s in 1, 2, 2.5, 5 sequence and 4 GS/s	
Resolution	10-bit	
Bandwidth	DC to 2 GHz	
Number of channels	Single at 4 GS/s	Dual at 2 GS/s, Single at 4 GS/s
Voltage Input	50 Ω: 50 mV to 5 V 1 MΩ: 50 mV to 50 V	
On-board Measurements	N/A	
Memory	256 kSamples/channel	512 kSample
Optional memory	256 MSamples/channel	512 MSample

Multi GHz bandwidth front-end

The front-end mezzanines include a proprietary front-end amplifier chip. This integrated circuit includes a programmable gain amplifier (PGA) with on-chip filtering and trigger circuitry. It provides pre-ADC signal conditioning and amplification, essential for high performance high-speed data conversion systems. The filter section, which is useful for signal noise reduction, allows 2-pole Bessel bandwidth limiting at 700 MHz and 200 MHz.

Trigger mezzanine with Ctrl I/O



The trigger mezzanine also includes the proprietary front-end amplifier chip. The trigger processing circuit embedded in the package includes

- Dual comparators for window triggering mode
- On-chip DACs for threshold adjustment
- Additional filters for LF and HF reject trigger coupling
- A prescaler to allow an HF divide-by-four mode

The trigger mezzanine provides access to the front-end amplifier chip via a standard 50 Ω terminated BNC or SMA connector and the Ctrl I/O. These four front-panel MMCX connectors provide access for an external clock or 10 MHz reference signal, a trigger output and two additional I/O digital control lines (I/O A and B) for monitoring or modifying the digitizer's status and configuration or extracting a 10 MHz clock signal.

Auto-synchronous bus system

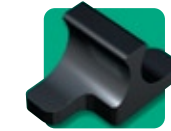

If more than two synchronous data acquisition channels are required, several digitizers can be combined using the second generation highbandwidth auto-synchronous bus system (AS bus 2). The system provides superior synchronization to the standard 10-MHz PXI reference clock. AS bus 2 connects up to three U1062A modules.



Options and Accessories

- U1062A-2F5 Dual-channel 50 ohm, 2 GHz front end
- U1062A-2HZ Dual-channel 1 Mohm / 50 ohm, 2 GHz front end
- U1062A-F50 Single-channel 50 ohm, 2 GHz front end
- U1062A-512 512 MSample acquisition memory
- U1062A-M64 64 MSample acquisition memory



Compact Multichannel Acquisition System with Embedded PC or Computer Interface



Chassis

- 3-, 5- or 8-slot CompactPCI chassis

Interface or Processor

- A choice of interfaces for desktop or laptop PC's or in system single-board computer

Software

- Turnkey AcqirisMAQS software for multichannel visualization, or standard software support for easy integration into your measurement system

Data Acquisition Modules

- Mix and match from a variety of digitizer, TDC or processing modules

U1056B High-Speed Data Converter Systems



Portable high-resolution system

This low power, 3-slot portable system provides 4 synchronized input channels with 12-bit resolution and a highspeed interface to a laptop PC with ExpressCard slot. Ideal for Telecom testing or Ultrasound systems.



High-speed data acquisition

The 5-slot crate provides four vacant slots to be used by Agilent data converter modules. By including 4 U1065A modules, synchronized using the AS bus 2 connectors, this system offers 16 high-speed (2 GS/s) data acquisition channels that to the embedded high-performance host processor look to be one single instrument.



Rack mountable 80-channel system

Held in a 21-slot 9U crate, this example system with 80 acquisition channels each running with a real-time sampling rate of 1 GS/s, has a power consumption of less than 900W. The whole system can sit on a desk or be mounted into a 19" rack. The AcqirisMAQS software allows easy control of the system and visualization of the acquired data through a desktop PC interfaced through the PCI bus. With 80 input channels, large scale experiments as in radio astronomy or particle physics, can be integrated and controlled in a single desktop solution.



Compact, Low-Power Digitizer that Maximizes Measurement Throughput

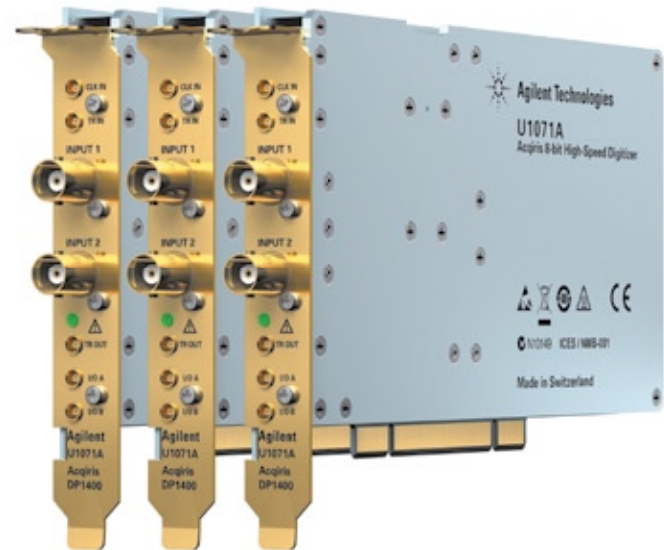

U1071A-001 Acqiris Dual-Channel, 1 GS/s High-Speed Digitizer

- 1 GHz bandwidth
- 256 kSample to 256 MSample acquisition memory
- Low power (15 W)

U1071A-002 Acqiris Dual-Channel, 1 GS/s High-Speed Digitizer

- 500 MHz bandwidth
- 256 kSample to 256 MSample acquisition memory
- Low power (15 W)

U1071A 2 GS/s 8-bit High-Speed PCI Digitizer

Models and specifications

	U1071A-001	U1071A-002	U1071A-004
Sample Rate	100 S/s to 2 GS/s in 1,2,5 sequence	100 S/s to 2 GS/s in 1,2,5 sequence	100 S/s to 1 GS/s in 1,2,5 sequence
Resolution	8 bits (1:256)		
Bandwidth	DC to 1 GHz	DC to 500 MHz	DC to 200 MHz
Number of channels	256 kS 128 kS/channel		
Voltage Input	50 Ω: 50 mV to 5 V 1 MΩ: 50 mV to 50 V		
On-board Measurements	N/A		
Memory	256 kS 128 kS/channel		
Optional memory	up to 256 MS/channel		

Trigger mezzanine with Ctrl I/O



The memory and acquisition controller of the U1071A digitizer is a digital CMOS integrated circuit.

SAR Mode

A high-speed data demultiplexer with on-board memory, it is designed for the capture and memorization of digital data (up to 10-bit), at speeds of up to 2 GS/s. It has large internal static RAMs, high clock frequencies, and is able to accept and generate LVDS (low-voltage differential signal, 100 mV - 600 mV range) levels for fast input/output signals. The circuit allows storage of the input data stream to a self-addressed, 256 ksamples, internal memory, and provides high throughput operation with the optional SAR mode. It also provides data handling for the 64, 128, and 256 Msample optional memory extensions.



Figure 1 High-speed U1071A dual channel digitizer

Options and Accessories

- U1071ATM1 Preconfigured with 1 GHz, 1 to 2 GS/s, 256 Msample acquisition memory
- U1071ATM2 Preconfigured with 500 MHz, 1 to 2 GS/s, 256 Msample acquisition memory
- U1071ATM4 Preconfigured with 200 MHz, 0.5 to 1 GS/s, 128 Msample acquisition memory
- U1071A-SAR Simultaneous multibuffer acquisition and readout firmware



High-Speed PCI Digitizer with Exceptional 12-bit Performance

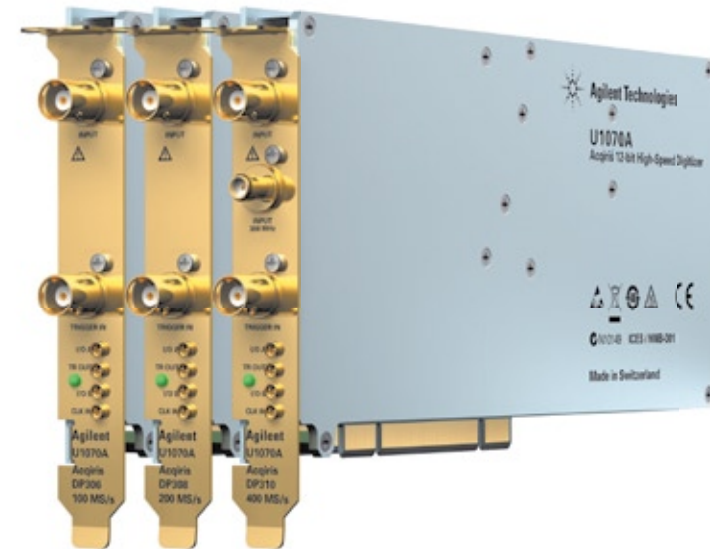

U1070A-001 Acqiris Single-Channel, 400 MS/s High-Speed Digitizer

- 100 MHz DC-coupled standard input, 300 MHz AC-coupled HF input
- 4 MSample acquisition memory
- High measurement throughput with PCI interface

U1070A-002 Acqiris Single-Channel, 200 MS/s High-Speed Digitizer

- 100 MHz bandwidth
- 4 MSample acquisition memory
- High measurement throughput with PCI interface

U1070A-003 Acqiris Single-Channel, 100 MS/s High-Speed Digitizer

- 50 MHz bandwidth
- 4 MSample acquisition memory
- High measurement throughput with PCI interface

U1070A 400 MS/s 12-bit High-Speed PCI Digitizer

Models and specifications

	U1070A-001	U1070A-002	U1070A-004
Sample Rate	100 S/s to 420 MS/s	100 S/s to 200 MS/s	100 S/s to 100 MS/s
Resolution	12 bits at SR >200 MS/s, 13 bits at SR =200 MS/s	12 bits at SR >110 MS/s, 13 bits at SR =110 MS/s	12 bits
Bandwidth	DC to 100 MHz	DC to 100 MHz	DC to 50 MHz
Number of channels	Single at 420 MS/s	Single at 200 MS/s	Single at 100 MS/s
Voltage Input		50 Ω: 250 mV to 10 V	
On-board Measurements		N/A	
Memory		4 MSamples/channel	
Optional memory		N/A	

Unique Tools for Complex Frequency Analysis

Agilent Acqiris high-speed PCI digitizers (U1070A) set the standard in high-resolution data acquisition. Using the latest technology, the digitizers provide fast sample rates of up to 420 MS/s and wide bandwidths of up to 300 MHz. The digitizers feature long 4 MSample acquisition memory. Waveforms are transferred directly into the digitizers' large acquisition memory so that complex signals can be stored over long time periods. Large memory is essential for maintaining fast sampling rates and timing resolution.

The sample rate selection and bandwidth combine to allow the high-resolution capture of signals with a high spurious free dynamic range (typ. 80 dB into the HF input and 75 dB otherwise) and a high signal-to-noise ratio (typ. 65 dB into the HF input, 62 dB otherwise). Additional outstanding specifications include typ. total harmonic distortion (THD) of -78 dB, very low noise floor spectrum at -90 dB and effective bits (ENOB) of more than 10.

Such specifications make the U1070A digitizers a perfect match for test and measurement applications in automotive, ultrasound, medical imaging, lidar, NDT, and high-accuracy analytical instruments. The HF input of the DP310 is ideal for wireless communication equipment testing, general QAM or RF/IF digital receivers, and radar wideband communication and analysis (SIGINT) applications.





Reconfigurable Data Converters Provide On-the-Fly Processing



U1080A-001 Acqiris Dual-Channel, 1-2 GS/s High-Speed Digitizer with on-board Signal Processing

- 1 GHz bandwidth
- 7 Mbits FPGA
- Optional external processing memory providing 512 MB of SDRAM and 1 MB dual-port SRAM
- Fiber optic data output

U1080A-002 Acqiris Dual-Channel, 1-2 GS/s High-Speed Digitizer with on-board Signal Processing

- 1 GHz bandwidth
- 7 Mbits FPGA
- Optional external processing memory providing 512 MB of SDRAM and 1 MB dual-port SRAM
- Fiber optic data output

U1080A 2 GS/s 8-bit High-Speed Digitizer with On-Board Signal Processing

Models and specifications

	U1080A
Sample Rate	100 S/s to 2 GS/s
Resolution	8-bit
Bandwidth	DC to 1 GHz
Number of channels	2 at 1 GS/s or 2 at 2 GS/s
Voltage Input	50 Ω: 50 mV to 5 V
On-board Measurements	Firmware dependant
Memory	Up to 7 Mbits on-chip RAM
Optional memory	512 MB DDR-SDRAM

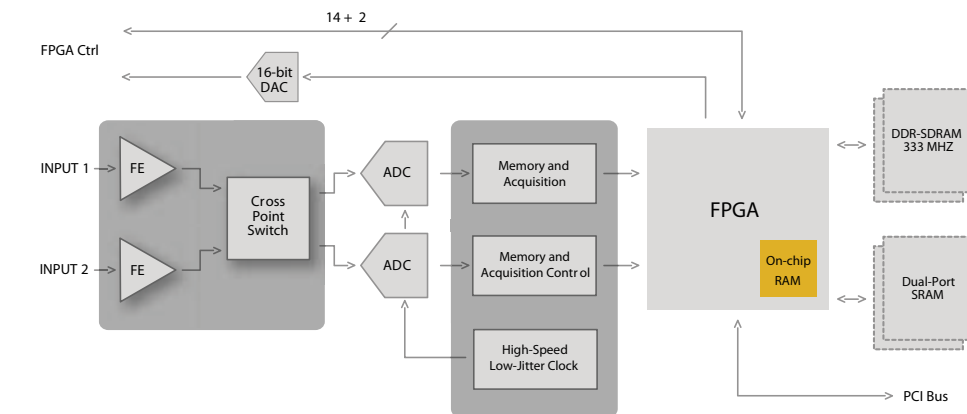

On-Board FPGA Processing

The U1080A is a dual-channel 8-bit CompactPCI®/PXI™ digitizer with on-board real-time data processing and fast front-panel data output. The platforms are designed to cover requirements encountered in radar, astronomy and, with fiber-optic output, similar mass storage-related applications. These data converters are particularly suited when direct sampling techniques are used and when signals must be sampled with high rates of up to 2 GS/s and an analog bandwidth of up to 1 GHz.

The modules provide on-board high-performance data processing by means of a very large FPGA. Raw or processed data can be transferred through front-panel optical transceivers at rates of up to 30 Gbps. The on-board FPGA allows the platforms to be easily reconfigured to perform user defined on-board real-time signal processing on the digitized signal.

Options and Accessories

- U1080A-FDK Firmware development kit for AC/SC platform
- U1080A-FFT 32 Kpoint FFT Analyzer firmware at 2 GS/s, only for -001
- U1080A-ODL High-rate optical data link, only for U1080A-002

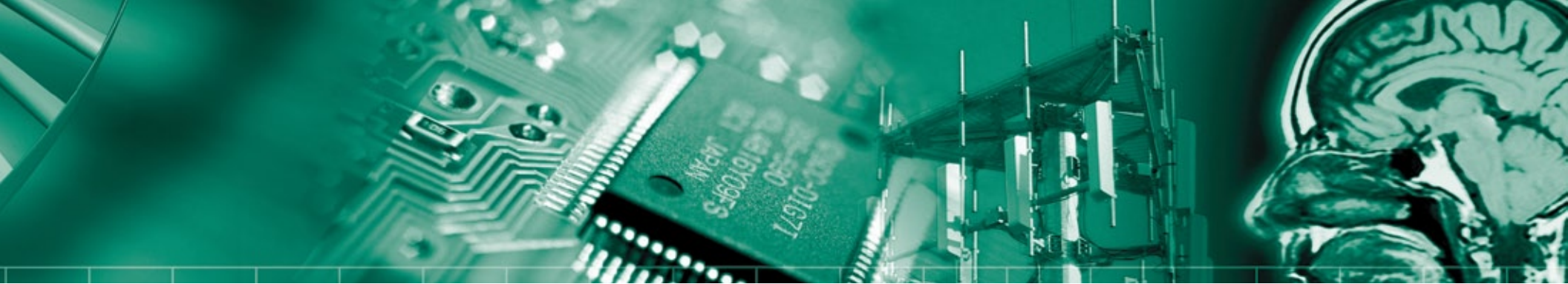

Flexible PCI Data Converters to Maximize Measurement Throughput

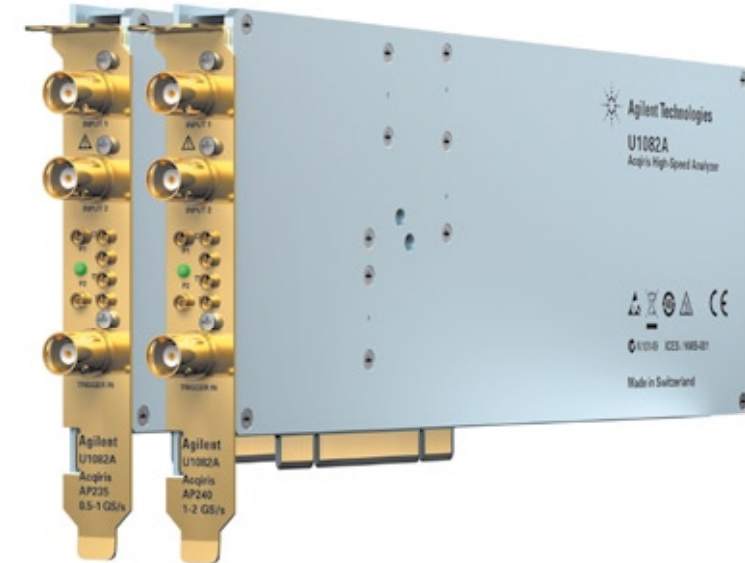

U1082A-001 Acqiris Dual-Channel, 1-2 GS/s High-Speed Digitizer with on-board Signal Processing

- 1 GHz bandwidth
- Processing memory from 6-12 MB up to 24-48 MB (optional)
- Firmware for signal averaging, peak detection and ping-pong data handling

U1082A-002 Acqiris Dual-Channel, 0.5-1 GS/s High-Speed Digitizer with on-board Signal Processing

- 500 MHz bandwidth
- Processing memory from 6-12 MB up to 24-48 MB (optional)
- Firmware for signal averaging, peak detection and ping-pong data handling

U1082A 2 GS/s 8-bit High-Speed PCI Digitizer with On-Board Signal Processing

Models and specifications

	U1082A-001	U1082A-002
Sample Rate	100 S/s to 2 GS/s	100 S/s to 1 GS/s in 1,2,2.5,4, 5 sequence
Resolution	8-bit	
Bandwidth	DC to 1 GHz	DC to 500 MHz
Number of channels	Dual at 1 GS/s, Single at 2 GS/s	Dual at 500 MS/s, Single at 1 GS/s
Voltage Input	50 Ω: 50 mV to 5 V	
On-board Measurements	Firmware dependant	
Memory	2 MSamples/channel of 24 bits 8 MSamples/channel of 24 bits (with – M24 option)	
Optional memory	6-12 MB up to 24-48 MB	6-12 MB up to 24-48 MB

Reconfigurable, on-the-fly processing

Two on-board FPGA's (Xilinx Virtex-2®) are reconfigurable or real-time operations. A family of firmware options enables the platform to perform a variety of user- or factory-defined on-the-fly processing tasks on the digitized data.



Options and Accessories

- U1082A-M24 24 MB processing memory for U1082A
- U1082A-SSR Firmware for sustained sequence recording
- U1082A-AVG Firmware for real-time sampling and averaging
- U1082A-TDC Firmware for time-to-digital conversion and peak analysis



LXI digitizers with a high performance front end and on-board measurements

- 20 MSamples per second
- 16-bit ADC Simultaneous sampling
- $\pm 250\text{mV}$ to $\pm 250\text{V}$ Isolated inputs
- AC or DC coupling
- Standard 32MS/Ch or Extended 128 MS/Ch memory
- On-board measurements
- Built-in Web Interface
- Gigabit LAN and HS USB 2.0 interfaces
- 1U, Full Rack stand alone instrument
- LXI Class-C compliant



L4532A 20 MS/s 16-bit High Resolution LXI Digitizer

Models and specifications

	L4532A
Sample Rate	20 MSa/s
Resolution	16-bit
Bandwidth	20 MHz
Number of channels	2 simultaneously sampling
Voltage Input	$\pm 250\text{ mV}$ to $\pm 250\text{ V DC}$, isolated
On-board Measurements	V min / V max, VPP, V avg / V rms, V top / V base, Rise/Fall time, Overshoot / Preshoot, Frequency / Period, Pulse width, Duty Cycle
Segmented Memory	32 MSamples/channel
Options	Extended Memory, 128 MSamples/channel



The Agilent L4532A and L4534A 20 MSa/s LXI digitizers offer 2 or 4 input channels in a stand-alone LXI format unlike the typical VXI, PXI and PCI digitizers available today. The digitizers have high performance front ends with isolated inputs and the ability to float up to 40V to accommodate differential signals. The voltage input is $\pm 250\text{mV}$ up to $\pm 250\text{V}$. A real benefit when analyzing high voltage and transient signals as seen in many automotive and aerospace defense applications.

The front end design eliminates many customers' needs for signal conditioning and attenuation that they are currently using with their digitizers. The LXI digitizers have Gigabit LAN for fast data transfers and on-board measurements. The on-board measurements are useful especially in manufacturing applications where measurement results are needed. Transferring the results eliminates the need for post processing and storing large sets of data, saving both time and money.

Save test time and money with high performance analog inputs
The digitizer's individually isolated channel inputs have been designed for high performance with an A/D converter per channel to ensure the signals you measure are accurately digitized without distortion or additional noise. Channel input range is configurable from $\pm 250\text{ mV}$ up to $\pm 250\text{ V}$ with a floating voltage up to $\pm 40\text{ V}$ to accommodate differential waveform acquisition. You can also choose to enable 2 MHz and 200 KHz input filters to your digitizer. The high voltage input, isolated inputs and selection of noise filters reduces the need to add expensive input signal attenuation and signal conditioning circuitry, saving test development time and money.

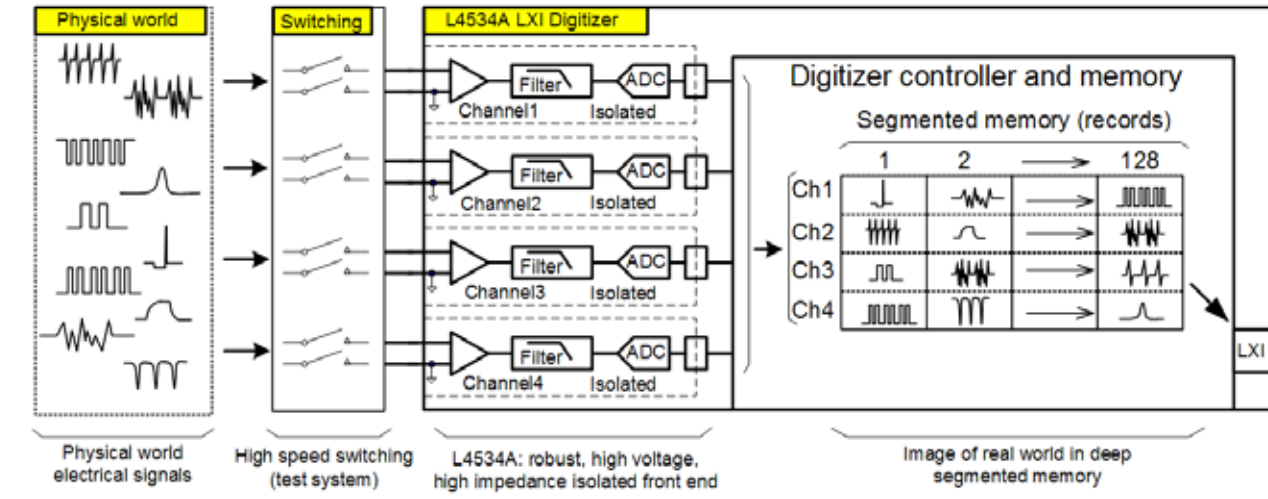

Options and Accessories

- Option 908 Rack mount kit L4532-67001 Includes Product Reference CD (Products doc and examples), IO Libraries CD, and Power Cord.
- Option 0B0 Deletes printed manual set (Full documentation included on CD ROM)
- Option ABA English printed manual set



LXI digitizers with a high performance front end and on-board measurements

- 20 MSamples per second
- 16-bit ADC Simultaneous sampling
- $\pm 250\text{mV}$ to $\pm 250\text{V}$ Isolated inputs
- AC or DC coupling
- Standard 32MS/Ch or Extended 128 MS/Ch memory
- On-board measurements
- Built-in Web Interface
- Gigabit LAN and HS USB 2.0 interfaces
- 1U, Full Rack stand alone instrument
- LXI Class-C compliant



L4534A 20 MS/s 16-bit High Resolution LXI Digitizer

Models and specifications

L4534A	
Sample Rate	20 MSa/s
Resolution	16-bit
Bandwidth	20 MHz
Number of channels	4 simultaneously sampling
Voltage Input	$\pm 250\text{ mV}$ to $\pm 250\text{ V}$, isolated
On-board Measurements	V min / V max, VPP, V avg / V rms, V top / V base, Rise/Fall time, Overshoot / Preshoot, Frequency / Period, Pulse width, Duty Cycle
Segmented Memory	32 MSamples/channel
Options	Extended Memory, 128 MSamples/channel

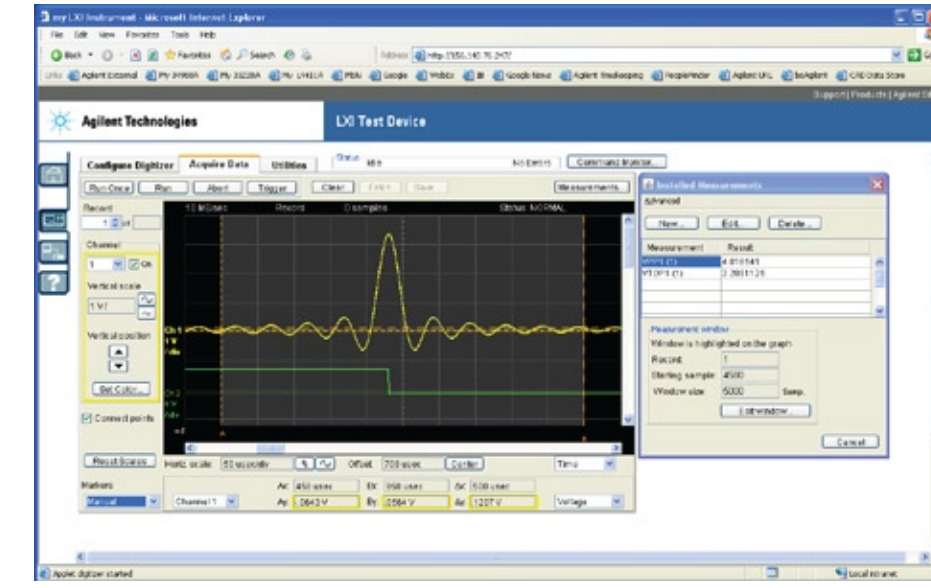

Connect to the digitizers' graphical web interface either by direct LAN or through the internet with your PC's Java-enabled web browser (i.e. Internet Explorer). Enter the IP address displayed on the front of the digitizer into the web browser address and you will be able to configure, acquire and display waveforms and measurements without programming. The web interface simultaneously displays the channel signals and measurements and provides an instrument command log that is very useful during development or debug.

Minimize post processing with onboard measurements
 The L4532A and L4534A digitizers include a collection of on-board "scope-like" measurements such as Vmin/Vmax, Vp-p, frequency, rise/fall time, and more that can be applied to a selected portion or the overall waveform. There is no need for post processing data to get the measurement results you need, saving time and minimizing the need to transfer and store large amounts of data. The waveform measurements are made within a user selected region of the digitized waveform and include their time position.



Control, Acquire, Measure, Evolve with USB Simultaneous Sampling Data Acquisition



- High-speed USB 2.0 (480MBit/s) TMC 488.2 compliant
- Standalone and modular capabilities
- 14-bit resolution, simultaneous analog input channels, up to 2 MSa/s/ch
- 2 12-bit analog output channels, 1 MSa/s analog output update rate
- 24-bit programmable TTL input/output channels
- 2 general purpose digital counter channels

U2531A 4-CH 14-bit 2 MSa/s Simultaneous Sampling Data Acquisition

Models and specifications

	U2531A
Sample Rate	2 MS/s
Resolution	14-bit
Bandwidth	1.2 MHz
Number of channels	4 Differential Input (analog); 24 bit programmable input/output channels (digital)
Voltage Input	+/- 10V (For Analog Inputs); V _{IL} = 0.7 V maximum; I _L = 10 μA maximum V _{IH} = 2.0 V minimum; I _H = 10 μA maximum (For Digital Inputs)
On-board Measurements	Frequency/Period, Pulse Width
Memory	8 MSa FIFO buffer



The Agilent U2500A Series USB simultaneous sampling multifunction data acquisition (DAQ) devices are high-performance modules that consist of three models — the U2531A, U2541A, and U2542A. The U2500A Series provides up to four channels with resolutions of 14-bit and 16-bit. The U2531A can sample up to 2 MSa/s for each channel with a resolution of 14 bits, while the U2541A and U2542A can sample up to 250 kSa/s and 500 kSa/s for each channel respectively with a resolution of 16 bits.

Options and Accessories

- U2901A Terminal block and SCSI-II 68-pin connector with 1-meter cable
- U2902A Terminal block and SCSI-II 68-pin connector with 2-meter cable



Control, Acquire, Measure, Evolve with USB Simultaneous Sampling Data Acquisition



- High-speed USB 2.0 (480MBit/s) TMC 488.2 compliant
- Standalone and modular capabilities
- 14-bit resolution, simultaneous analog input channels, up to 250 kSa/s/ch
- 2 12-bit analog output channels, 1 MSa/s analog output update rate
- 24-bit programmable TTL input/output channels
- 2 general purpose digital counter channels

U2541A 4-CH 16-bit 250 kSa/s Simultaneous Sampling Data Acquisition

Models and specifications

	U2541A
Sample Rate	250 kSa/s
Resolution	16-bit
Bandwidth	600 kHz
Number of channels	4 Differential Input (analog); 24 bit programmable input/output channels (digital)
Voltage Input	+/- 10V (For Analog Inputs); V _{IL} = 0.7 V maximum; I _{IL} = 10 μA maximum V _{IH} = 2.0 V minimum; I _{IH} = 10 μA maximum (For Digital Inputs)
On-board Measurements	Frequency/Period, Pulse Width
Memory	8 MSa FIFO buffer

Product outlook and dimensions

Front view



Rear view



Top view

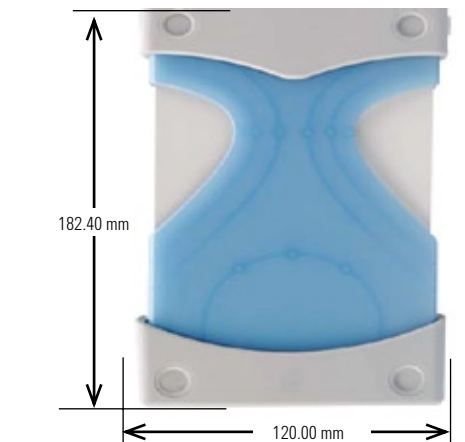

Standard Shipped Accessories

- AC/DC Power Adapter
- Power Cord
- USB Extension Cable
- L-Mount Kit (used with modular product chassis)
- Agilent U2500A Series USB Multifunction Simultaneous Sampling DAQ Devices Quick Start Guide
- Agilent Measurement Manager for U2500A Series Quick Start Guide
- Agilent USB Modular Products Reference CD-ROM
- Agilent Automation-Ready CD (contains the Agilent IO Libraries Suite)
- Certificate of Calibration

Options and Accessories

- U2901A Terminal block and SCSI-II 68-pin connector with 1-meter cable
- U2902A Terminal block and SCSI-II 68-pin connector with 2-meter cable

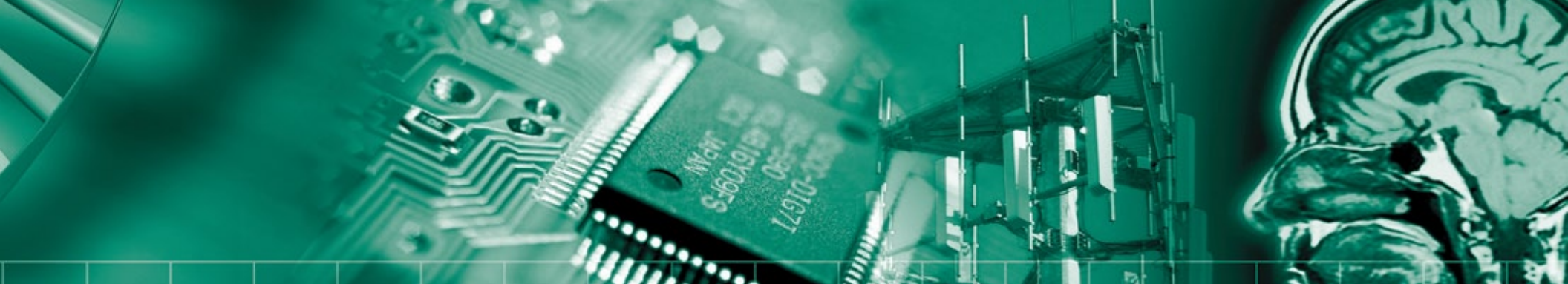

Control, Acquire, Measure, Evolve with USB Simultaneous Sampling Data Acquisition



- High-speed USB 2.0 (480MBit/s) TMC 488.2 compliant
- Standalone and modular capabilities
- 14-bit resolution, simultaneous analog input channels, up to 500 kSa/s/ch
- 2 12-bit analog output channels, 1 MSa/s analog output update rate
- 24-bit programmable TTL input/output channels
- 2 general purpose digital counter channels

U2542A 4-CH 16-bit 500 kSa/s Simultaneous Sampling Data Acquisition

Models and specifications

	U2542A
Sample Rate	500 kSa/s
Resolution	16-bit
Bandwidth	1 MHz
Number of channels	4 Differential Input (analog); 24 bit programmable input/output channels (digital)
Voltage Input	+/- 10V (For Analog Inputs); V _{IL} = 0.7 V maximum; I _L = 10 μA maximum V _{IH} = 2.0 V minimum; I _H = 10 μA maximum (For Digital Inputs)
On-board Measurements	Frequency/Period, Pulse Width
Memory	8 MSa FIFO buffer

Typical Performance Graph

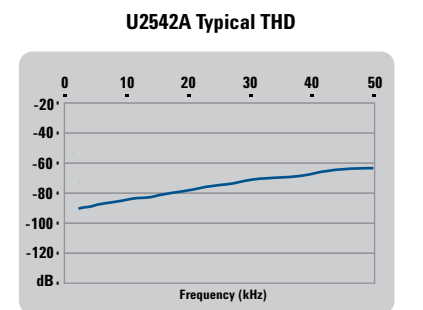
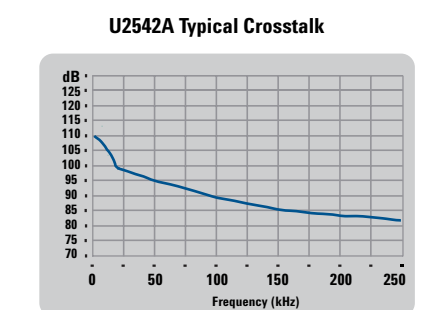
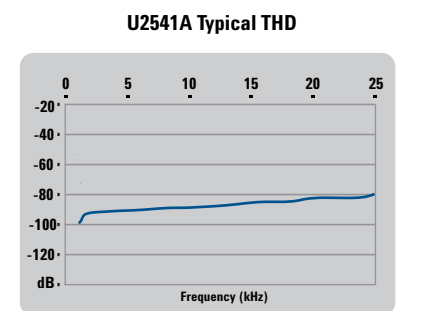
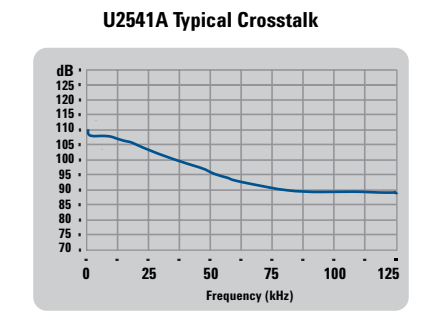
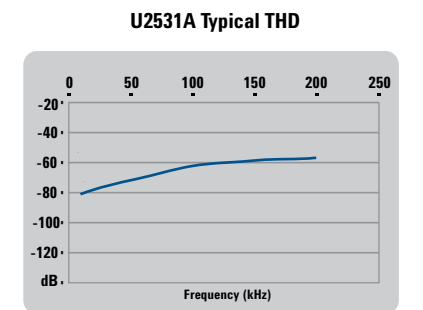
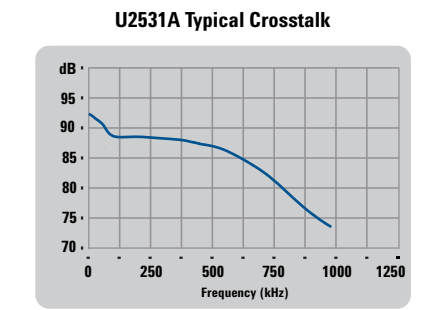

Options and Accessories

- U2901A Terminal block and SCSI-II 68-pin connector with 1-meter cable
- U2902A Terminal block and SCSI-II 68-pin connector with 2-meter cable

Digitizer Application Examples

Frequency Domain

- Communication (I&O)
- Audio test
- Ultrasound & Life Sciences
- Hard disk drive and semiconductor testing
- Astrophysics
- Electronic warfare

Time Domain

- Electromechanical device (motors, solenoids, drives, printer heads) testing
- Product characterization (ECU's,)
- Semiconductor characterization (diode, MOSFET)
- Synthetic instrument with small form factor for A/D
- Time of flight measurement (Radar, Lidar, Ultrasound, Particle acceleration)

Scanning Digitizers (slow sampling, long test durations)

- Data logging
- Physical test, mechanical test
- Data acquisition (thermal, strain)



DVD Players and Recorders

- Measurement of fast rise times, pulse widths and peak heights in the DUT
- High-speed data acquisition technology provides flexibility and low operational cost

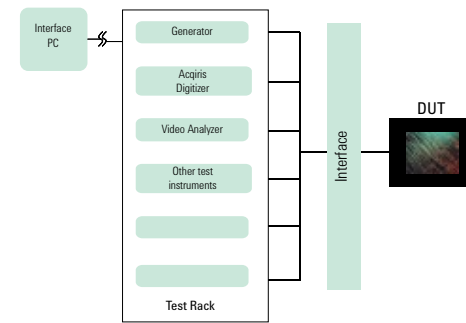

Signal Integrity → measure less and increase test speed



Neutron Capture for Nuclear Waste Reduction (CERN)

- Neutron detectors connected to digitizers (8 synchronized channels at 1 GS/s)
- Measurement of neutron detection

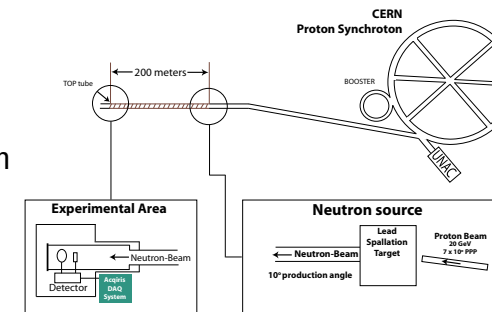

Signal Integrity → increased measurement resolution by 10X



Non-destructive Testing within Microelectronic Packages

- High frequency ultrasound is used to detect voids, cracks and delaminations
- Measurement of time of flight, velocity and magnitude of the ultrasound on the DUT

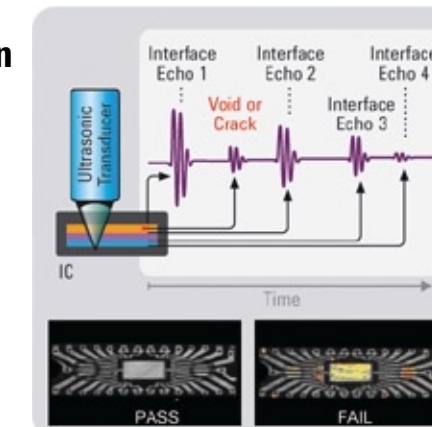

Signal Integrity → fewer false "pass" and "fail" increasing yields and lowering production costs



ECU Testing

- Front end isolation and high voltage input needed to test electro-mechanical DUTs
- Measurement of current sensors, solenoid fly-back voltages

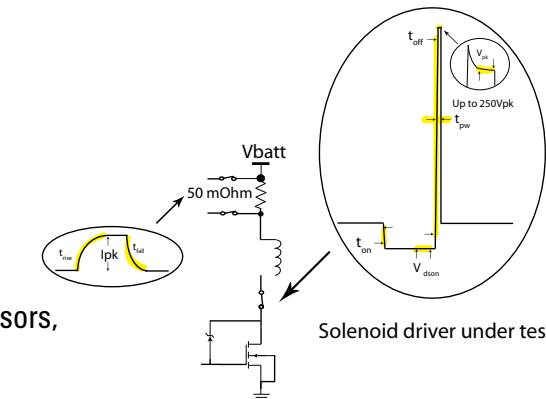

Signal Integrity → isolated front end allows accurate current sensing at high voltages



www.agilent.com

For more information on Agilent Technologies' products, applications or services, please contact your local Agilent office. The complete list is available at:

www.agilent.com/find/contactus

Microsoft is a US registered trademark of Microsoft Corp.

Product specifications and descriptions in this document subject to change without notice.

Phone

Americas

Canada	(877) 894-4414
Latin America	305 269 7500
United States	(800) 829-4444

Asia Pacific

Australia	1 800 629 485
China	800 810 0189
Hong Kong	800 938 693
India	1 800 112 929
Japan	81 426 56 7832
Korea	080 769 0800
Malaysia	1 800 888 848
Singapore	1 800 375 8100
Taiwan	0800 047 866
Thailand	1 800 226 008

Europe

Austria	01 36027 71571
Belgium	32 (0) 2 404 93 40
Denmark	45 70 13 15 15
Finland	358 (0) 10 855 2100
France	0825 010 700* (0.125 EUR HT/minute)
Germany	49 07031 464 6333
Ireland	1890 924 204
Italy	39 02 92 60 8484
Netherlands	31 (0) 20 547 2111
Spain	34 (91) 631 3300
Sweden	0200-88 22 55
Switzerland	0800 80 53 53 (German Opt 1) (French Opt 2)
United Kingdom	44 0 1189 276201
Other European countries:	www.agilent.com/find/contactus

Remove all doubt

Your equipment restored to like new performance, returned on time

Our repair and calibration services will get your equipment back to you performing like new, when promised. You will get full value out of your Agilent equipment throughout its lifetime. Your equipment will be serviced by Agilent-trained technicians using the latest factory calibration procedures, automated repair diagnostics and genuine parts. You will always have the utmost confidence in your measurements.

Agilent offers a wide range of additional expert test and measurement services for your equipment, including initial start-up assistance onsite education and training, as well as design, system integration, and project management.

For more information on repair and calibration services, go to www.agilent.com/find/removealldoubt

© Agilent Technologies, Inc. 2009
Published in The Netherlands,
January 26, 2009
5990-3505EN



Agilent Technologies